

Installation, Operating and Maintenance Manual

Gas Pressure Regulator Type SBV 12

Table of content

- 1. General information on installation, operating and maintenance instructions**
 - 1.1 Hazard notices
 - 1.2 Qualified staff
- 2. Functional description**
 - 2.1 Identification
 - 2.2 Sectional drawing / installation example
 - 2.3 Operation
- 3. Installation, operating instructions**
 - 3.1 Installation/assembly
 - 3.2 Pipe connections
 - 3.3 Commissioning
- 4. Inspection and maintenance**
 - 4.1 Inspection / maintenance
 - 4.2 Inspection before commissioning / recurring service inspections
- 5. Technical documentation**
 - 5.1 Spare parts drawing
 - 5.2 Spare parts list
- 6. Disposal**
- 7. Inspection certificates/certificates/certifications***
- 8. Documentation of included components**

*Will be enclosed here depending on the scope of the order

1. General on installation, operating and maintenance manual

1.1 Hazard notices

These instructions comply with EC safety standards, EC directive 97/23/EC (Pressure Equipment Directive) and the relevant rules and regulations of the Federal Republic of Germany.

When the valve is used outside the Federal Republic of Germany, those responsible for the design and operation of the plant must ensure that the relevant standards and national rules and regulations are observed.

This manual contains the instructions to install and operate the valve safely and in the prescribed manner. If difficulties or problems arise that cannot be solved with the aid of this manual, further information can be obtained from the manufacturer. Ignoring the above may cause damage to property, environmental damage and personal injury.

The manufacturer reserves all rights to make technical changes and improvements at any time.

The use of these instructions requires the user to be qualified as described in Section 1.2. The operating staff must be instructed according to the instructions.

1.2 Qualified staff

Qualified staff are persons who from their training and experience are familiar with the installation, mounting, commissioning, operation and maintenance of the regulator apply. They may carry out inspections, functional checks, maintenance and re-commissioning. At plants regulated by the German Association for Gas and Water (DVGW), a second person must be present.

2. Functional description

The Type 12 safety relief valve (SRV) has the function to release the flow of gas from a pressurised pipe automatically when the pressure in the system to be protected with rising tendency reaches the set response pressure. The SRV closes automatically when the pressure in the system to be protected drops below the closing pressure.

It is used for all gases according to DVGW worksheet G260 and all non-corrosive gases.

There are special versions available for other gases.

The safety relief valve may only be used as intended and exposed to the maximum pressure as indicated on the factory nameplate (see 2.1 Identification).

Design, construction and manufacturing are based on lifetime-limiting features, e.g. creep strength of pressure-bearing components. These features limit the permissible period of use.

2.1 Identification

A nameplate is used for identification

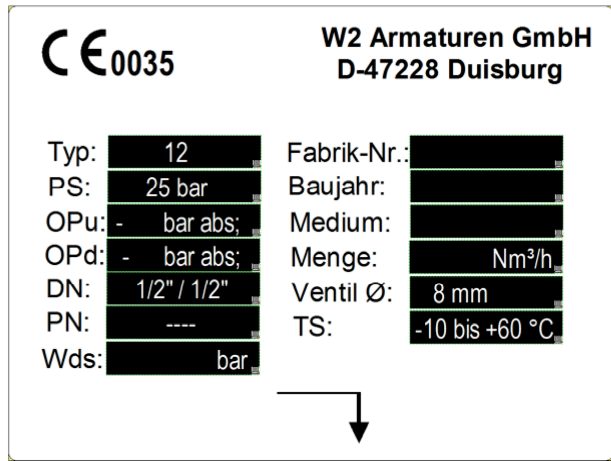

CE according to PED

PS: Pressure Stage

W_{ds}: Specific Set Input Range (Adjustment Range)

2.2 Sectional drawing / installation example

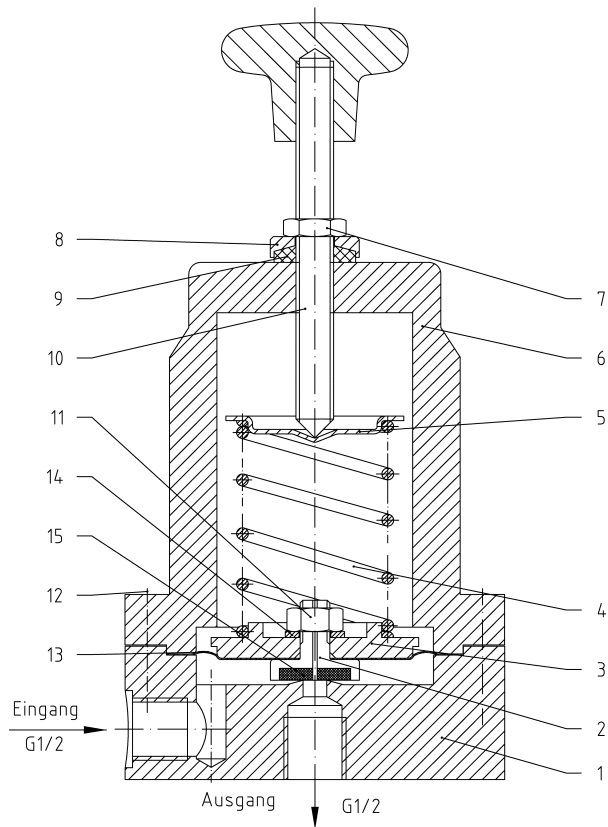

2.3 Function (according to the sectional drawing)

The Type 12 safety relief valve is a direct-acting spring-loaded device (without auxiliary power supply).

The pressure to be secured passes through the input line below the diaphragm 13 which is loaded by the spring 4. If the pressure rises too high and exceeds the setting of the spring 4, the diaphragm 13 lifts and with it the valve 2. The excess pressure is released into the air through the output line. If the pressure drops below the spring set point, the spring action closes the valve 2.

3. Installation, operating instructions

3.1 Installation/assembly

The Type 12 SRV can be installed in any position. The output must be into the free air.

3.2 Pipe connections

Solderless pipe connections with cutting ring according to DIN 2353

Ventilation G ¼" pipe for Ø12x1.5

Input/ output G ½" for pipe Ø16x1.5

3.3 Commissioning

The safety relief valve is ready for operation as soon as it is properly installed.

4. Inspection and maintenance tasks

4.1 Inspection/maintenance

Special maintenance of the SRV is not required. Malfunctions can occur only through dirt or damage to individual components.

For the installation and the equipment as well as the monitoring and maintenance of safety equipment, the respective regulations, but in particular the DVGW G490, G491 and G495 worksheets, must be complied with.

The maintenance intervals depend on the operating conditions and the nature of the gas used. Rigid maintenance intervals are therefore not specified, the responsibility lies with the operator.

All work on the SRV or its environment must be carried out in an unpressurised state. The national provisions, the guidelines of the operator and the manufacturer's instructions must be followed.

4.2 Inspection before commissioning / recurring service inspections

The operator must do and document service inspections before commissioning and at regular time intervals. The intervals specified in the DVGW worksheet 495 apply.

Inspections relating to, among other, compliance with the construction requirements, equipment integration, leaks and function with due regard to the DVGW worksheet 491.

5. Technical documentation

5.1 Spare parts drawing

See 2.2 Sectional Drawing

x: Keep wear parts in stock for maintenance.

5.2 Spare parts list

Item	Quant	Unit	Designation	Standard /	Material / remarks
1	1	Piece	Diaphragm housing	4-SBV-1	Al
x2	1	Piece	Valve	4-SBV-2	Ms
3	1	Piece	Diaphragm plate	4-St-9/H	Al
4	1	Piece	Set point spring	4-SBV-3/...	Spring steel C.
5	1	Piece	Spring cup	4-St-13	St, chromated
6	1	Piece	Diaphragm housing top	4-St-18/H	Al
7	1	Piece	Hexagon nut	DIN 431, G1/4	St, galvanised
8	1	Piece	Press ring	4-St-15	Ms
9	1	Piece	Stem seal	4-St-14	Perbunan
10	1	Piece	Palm grip with spindle	4-St-17	Ms, Duroplast
11	1	Piece	Hexagon nut	DIN 934, M10	St, galvanised
12	8	Piece	Socket screw	DIN 912, M6x20	8.8, galvanised
x13	1	Piece	Diaphragm	4-St-8/H	Perbunan
14	1	Piece	Disc	DIN 125, 10.5x2.5	St, galvanised
x15	1	Piece	Valve seal	~24x4	Perbunan

6. Disposal

Environmental damage can occur during disposal when the equipment still contain poisonous fluid residues.

It is therefore essential to ensure that the equipment is cleaned and free of fluid residues before disposal.

After that, all materials can be disposed of according to the regulations applicable at the operating site.